

Sleeping Car

Design:

VICO MAGISTRETTI
2004



+ info: <https://www.depadova.com/materials.pdf>

De Padova srl - info@depadova.it

DOUBLE BED

Materials

Headboard

structure in steel and wood. Padding in polyurethane foam and polyester wadding covered with light polyester velvet. For the FR (Fire Resistant) versions on request, the filling materials comply with the current regulations.

Base

powder-coated steel structure. Slats in bent beech plywood. Bed frame in plywood panel (class E1, CARB P2 / TSCA Title VI certified), padded with polyurethane foam and covered with light polyester velvet. Legs in black powder-coated steel, thermoplastic adjustable feet.

Cover

technically removable cover.

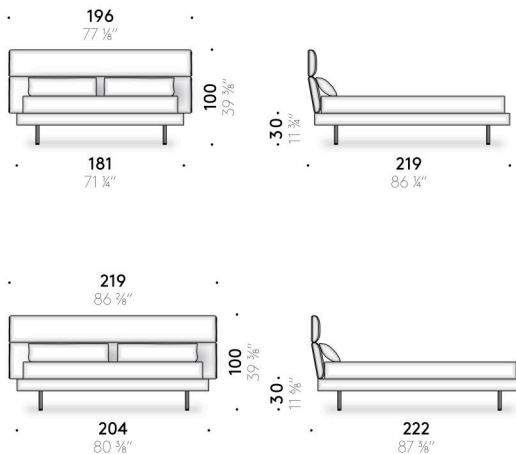

Sleeping Car

Design:

VICO MAGISTRETTI
2004



+ info: <https://www.depadova.com/materials.pdf>

De Padova srl - info@depadova.it

LETTO MATRIMONIALE

Materiali

Testiera

struttura in acciaio e legno. Imbottitura in poliuretano espanso e ovatta di poliestere, foderato con vellutino di poliestere. Per le versioni FR (Fire Resistant) a richiesta, i materiali dell'imbottitura sono come da normative.

Base

struttura in acciaio verniciato a polvere. Doghe in multistrato curvato di faggio. Giroletto in pannello di multistrato (certificato classe E1, CARB P2 / TSCA Title VI), imbottitura in poliuretano espanso foderato con vellutino di poliestere. Gambe in acciaio verniciato nero a polvere con piedini regolabili in termoplastica.

Rivestimento

rivestimento tecnicamente sfoderabile.

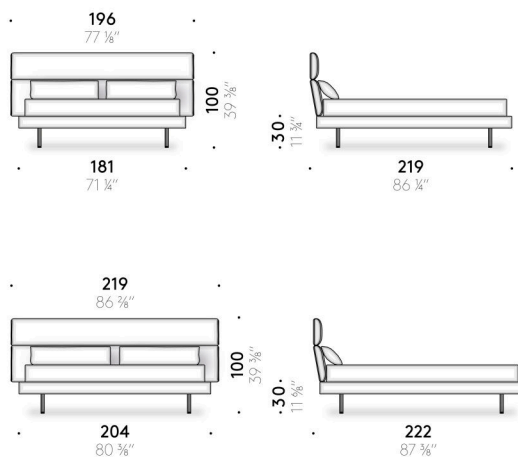

Sleeping Car

Design:

VICO MAGISTRETTI
2004



+ info: <https://www.depadova.com/materials.pdf>

De Padova srl - info@depadova.it

LIT À DEUX PLACES

Matériaux

Tête de lit

structure acier et bois. Rembourrage en mousse de polyuréthane et ouate de polyester, doublé en velours de polyester. Pour les versions FR (Fire Resistant) sur demande, les matériaux de rembourrage sont conformes à la réglementation

Base

structure acier peint à poudre. Lattes en multiplis de hêtre cintré. Pourtour du lit en panneau de multiplis (certifié classe E1, CARB P2 / TSCA Title VI), rembourrage en mousse de polyuréthane doublé en velours de polyester. Piètements en acier peint noir à poudre avec pieds réglables en thermoplastique.

Revêtement

revêtement techniquement déhoussable.

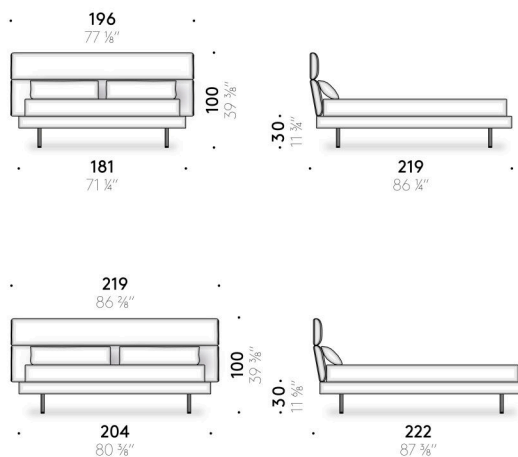

Sleeping Car

Design:

VICO MAGISTRETTI
2004



+ info: <https://www.depadova.com/materials.pdf>

De Padova srl - info@depadova.it

DOPPELBETT

Materialien

Kopfende

Stahl-und Holzgestell. Polsterung aus Polyurethanschaum und Polyesterwatte mit Überzug aus Polyestersamt. Bei den FR-Versionen (Fire Resistant), die auf Anfrage erhältlich sind, entsprechen die Polstermaterialien den geltenden Bestimmungen.

Gestell

Stahlgestell mit Pulverlackierung. Latten aus gebogenem Buchenmehrschichtholz. Bettrahmen aus Mehrschichtpaneel (zertifiziert Klasse E1, CARB P2 / TSCA Title VI), Polsterung aus Polyurethanschaum mit Überzug aus Polyestersamt. Beine aus Stahl mit Pulverlackierung schwarz, verstellbare Thermoplast-FüÙe.

Bezug

technisch abnehmbarer Bezug.

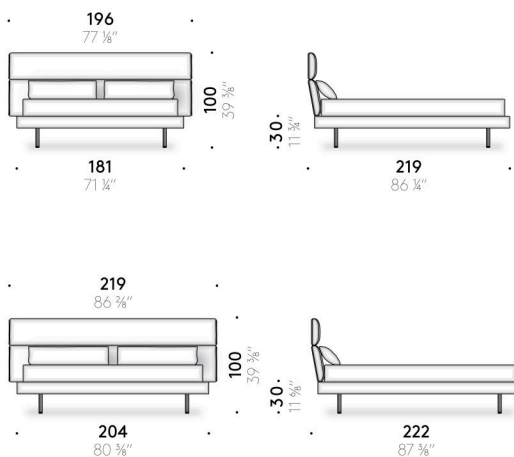

Sleeping Car

Design:

VICO MAGISTRETTI
2004



+ info: <https://www.depadova.com/materials.pdf>

De Padova srl - info@depadova.it

CAMA MATRIMONIAL

Materiales

Cabecero

estructura de acero y madera. Relleno de espuma de poliuretano y guata de poliéster, tapizadas con terciopelo de poliéster. Para las versiones FR (Fire Resistant) bajo pedido, los materiales del relleno cumplen con las normativas.

Base

estructura de acero pintado en polvo. Láminas de multicapa curvada de haya. Base de la cama de panel de multicapa (certificado clase E1, CARB P2 / TSCA Title VI), relleno de espuma de poliuretano tapizada con terciopelo de poliéster. Patas de acero pintado negro al polvo con pies ajustables de termoplástico.

Revestimiento

revestimiento técnicamente desenfundable.

